

# Backfill materials for Mechanically Stabilized Earth (MSE): African Experience

## Matériaux de remblai pour la terre mécaniquement stabilisée (MSE) : Une expérience africaine

Andrew C S Smith

*Reinforced Earth (Pty) Ltd Johannesburg, South Africa*

Leon Dison

*Reinforced Earth Mining Services (Pty) Ltd, Johannesburg, South Africa*

### ABSTRACT

Since 1975, Reinforced Earth (Pty) Ltd (RESA), based in South Africa has been carrying out MSE projects in South Africa itself and also in African countries outside its borders. The company has acquired experience of diverse types of backfill, which are often derived from weathered residual soils rather than transported gravels found extensively in Europe and North America. Experience in the use of industrial waste materials has also been gained. This paper reviews the types of backfill used and concentrates on the problems encountered. It also discusses methods of locating sources of suitable material and the possibility of formulating a revised and wider range of backfill specifications for MSE structures.

### RÉSUMÉ

Depuis 1975, Reinforced Earth (Pty) Ltd (RESA) établie en Afrique du Sud a réalisé des projets d'ouvrages en sols renforcés dans ce pays et également dans de nombreux autres pays du continent Africain. La société s'est ainsi forgé une expérience dans des types de remblais variés provenant souvent de sols résiduels altérés plutôt que de remblais granulaires transportés sur les sites de construction comme cela est généralement le cas en Europe et en Amérique du Nord. Une expertise dans l'utilisation de matériaux industriels de récupération a également été acquise. Cet article passe en revue les types de matériaux de remblais utilisés en apportant un éclairage sur les problématiques rencontrées. Sont également discutées des méthodes de localisation de sources de matériaux convenables et la possibilité de revoir et d'élargir le spectre des spécifications de remblais pour les ouvrages en sols renforcés.

Keywords : Reinforced Earth®; mechanically stabilized embankments; backfill; African experience

## 1 INTRODUCTION

MSE is a composite material comprising backfill material (usually earth), reinforcements and in most cases, a cladding. Its strength is derived by way of the frictional interaction between the backfill and the reinforcements. "Permanent" MSE structures are generally required to have service lives in excess of 70 years. Consequently the constituent materials need to be durable and the frictional relationship between earth and reinforcement should be maintained throughout the required service life.

## 2 BACKFILL SPECIFICATIONS AND CLASSIFICATION

The grading of the backfill should be such that the maximum size is no larger than  $\frac{2}{3}$  the compaction layer thickness. The fine non-frictional material should be confined to the volume which would fill the voids in frictional material, but should not separate the frictional particles from each other.

The percentage of fines less than 20 microns is used by RESA to classify the potential backfill as follows:

- "Granular" soils which have good internal friction and which remains almost unaffected by the presence of water (<10% passing 20 micron).
- "Intermediate " soils which are frictional, but less so if poorly drained (10%-40% passing the 20 micron)
- "Fine" soils which drain very slowly and have no frictional properties on a short term basis (40% passing the 20 micron ). Fine soils should not be used for MSE structures.

Reinforcing strips are embedded in the backfill for the service life of the structure. The electro-chemical properties of the backfill need to be tested to ensure that the reinforcing strips will not corrode or deteriorate with time and will be able to

provide adequate strength and friction characteristics for the service life of the structure.

## 3 BACKFILL EXPERIENCE GAINED IN AFRICA

Reinforced Earth (Pty) Ltd has been operating in Africa since 1975 and has carried out approximately 500 contracts of which some 90 have been located outside South Africa. By the end of 2008 countries in Africa for which RESA has designed and supplied materials are: South Africa, Botswana, Lesotho, Swaziland, Mozambique, Angola, Namibia, Zimbabwe, Zambia, Tanzania, Malawi, DRC, Uganda, Mali, Gabon, Burkino Faso, Ghana, Nigeria, Guinea, Cote d'Ivoire, Mauritania, Madagascar, Reunion Island, Ethiopia, Eritrea, Sudan. Other Reinforced Earth companies in the Group have also operated in Africa's Morocco, Libya, Algeria, Tunisia, Egypt and Cameroon.

The area of Africa is 30.7 million square kilometres and the continent's geology comprises a basement of old metamorphic rocks with granitic intrusions overlain in parts by shallow sedimentary rocks. The continent has not been subjected to extensive glaciations as has N America and Europe and therefore the available soils mainly comprise residual soils rather than transported soils that are often available in Europe and N America.

The backfills of which RESA has had experience can be classified:

### 3.1 *Residual soils- developed from the weathering of the underlying bedrock*

Residual soils are the most commonly used MSE backfill material used in Africa and selection of the coarsest of these generally produces a material which is borderline between

granular and intermediate backfill. In RESA's experience the coarsest residual materials have been a laterite with 6% passing 20 micron (Norton Zimbabwe 1982) and a weathered dolerite with 10% passing 20 micron (Tombo Port St Johns 1990). The most common of the residual soils used have been weathered granites and felsites, while schists and gneisses have also been used on occasion. In the case of weathered granites the uppermost weathered red coloured material is too fine to use as backfill, the less weathered brown and yellow granite is intermediate and only the white-coloured least weathered material may be coarse enough to be classified as granular. For design purposes granular materials are generally assumed to have an internal friction angle of at least 36°, but all intermediate backfills are tested to determine their angle of friction for design purposes. Residual intermediate soils are generally highly frictional with angles of friction above 36° being the norm.

When using intermediate materials care is required both during and after the construction to prevent ingress of water into the backfill. Sufficient surface and sub surface drainage is therefore installed to prevent ingress of water into the MSE mass during its service life. Walls using intermediate residual backfill have in general performed successfully. There are however a number of structures with intermediate backfill where movements have occurred both during and after construction resulting in settlements with consequent bulges and distress in the cladding.

Two specific cases in which problems have occurred using intermediate materials are described below.

### 3.1.1 Cru-Klipfontein tip wall – Mpumalanga RSA constructed in 1999

The structure is a 30m high tip wall placed 15m below natural ground level and 15m above natural ground level. The backfill used below ground was residual felsite (very fine grained volcanic rock) with 16% less than 20 micron. The above ground backfill was hillwash with 25-30% passing the 20 micron sieve and friction angle ranging from 27.7 to 32.5 degrees. Post construction settlement of the upper part of the structure bearing on the lower structure is almost linear and is ongoing. Settlements of the order of 30 mm per year occurred between 2000 and 2006 with little sign of slowdown. These settlements have caused movement in the cladding, but do not effect the overall integrity of the structure. (See Figure 1)



Figure 1. Cru-Klipfontein tip wall

### 3.1.2 Kloofpass bridge approaches – Limpopo RSA constructed in 2000

The backfill properties were those of an intermediate backfill with 20-30% less than 20 microns and angle of internal friction of the order of 36 degrees for both rapid and slow saturated shear tests at 93% Mod AASHO. Construction was almost complete when a severe rainstorm struck the site and ingress of water into the MSE mass led to progressive collapse settlement,

which is defined as the additional settlement and stress changes that a soil undergoes when its moisture content increases. It is postulated that the clay bridges in the inadequately compacted backfill collapsed as they became saturated and progressive failure of the MSE ensued (Figure 2). Piles have subsequently been driven through the failed MSE embankment and support bridge decks replacing the approach embankments.



Figure 2. Kloofpass bridge approaches

### 3.2 Transported soils

Transported soils are deposited by agents such as ice, water and wind and not derived from the underlying bedrock. Considerable experience has been gained with transported sands and in particular with beach sands, river sands and aeolian sands.

Beach and river sands are granular materials and are often single-sized.

The river sands are free draining and ideal backfill materials, but are generally scarce and consequently seldom available or economically viable. The beach sands are often precluded when using steel reinforcements on account of their salt content, but can be used with synthetic reinforcing strips.

A great deal of experience has been gained with the dune sands of the Cape which are wind-blown sands from ancient beaches and are fine and single sized. Notwithstanding these materials being granular (less than 10% passing the 20 micron) care should be taken to measure their angle of internal friction. On account of their fineness and single size some of these sands can have friction angles as low as 30 degrees. The moisture density curve for these sands is flat, requiring a moisture content that enables trucks and compaction equipment to travel on the backfill. When using steel reinforcement the electrochemical properties of compaction water need to be tested for suitability.

A further concern with single sized fine sands is leaching or spilling of backfill through the cladding. A durable geofabric backing is required behind all joints, and great care needs to be taken with structures alongside waterways and the sea that are subject to changing water levels. (Figure 3)



Figure 3. Church Street under construction

### 3.3 Aeolian soils

Aeolian soils of the interior, are sandy soils which have undergone redistribution by wind action and cover almost half of Southern Africa. Grading envelopes of these sands may be uniform except for varying amounts of clay. They could well be intermediate with clay content above 20%. When used in MSE structures care should be taken to compact the backfill adequately to prevent future collapse settlement. Figure 4 shows failure of an MSE structure in Limpopo, South Africa, due to inadequate compaction and subsequent collapse settlement.



Figure 4. Grootegeluk

### 3.4 Industrial wastes

In South Africa experience has been gained with three types of material.

- blast furnace slag
- steel slag
- RAP (recovered asphalt product)

In all cases galvanized steel reinforcing strips were used.

#### 3.4.1 Blast furnace slag

Blast furnace slag has been successfully used on 3 contracts: Faerie Glen, constructed in 1980; a structure inside the Iscor Steel Works Pretoria, constructed in 1978; a storage structure at Iscor Vanderbijlpark, constructed in 1983. The properties of the slag were consistent with pH 10.7, chloride content 35ppm and sulphate content 1680ppm. The material is an even-graded free draining gravel with 100% passing 70mm and 5% the 0.075. The electro-chemical properties fall outside the standard specifications for steel reinforcements. Sample strips were placed in the Faerie Glen backfill during construction in 1980 and extracted 14 years later in 1994. Tests showed only a small loss of zinc and no measurable loss of strength. This was also the case for test strips extracted from the Vanderbijlpark structure in 1995 after 12 years. These excellent durability results are attributed to the free draining nature of the backfill. (See Figure 5.)

#### 3.4.2 Steel slag

Steel slag was used for the Dunswart bridge complex constructed using galvanized steel reinforcing strips in 1987. The properties of the slag were as follows.

Mechanical: granular with 100% passing the 75 mm sieve and 2% the 0.075; grading modulus 2.71.

Electro-chemical: pH 8.2-12.4; chlorides 7-28 ppm; sulphates 432-1229 ppm; sulphides 0-1992 ppm.

Test strips were extracted in 1992 after 5 years and again in 1998 after 11 years. A sample of backfill was also removed in

1992. Durability of the strips has proved satisfactory with little loss of mass and no measurable loss of strength.

In 1998 however, RESA was alerted to cracking of the panels. Investigation determined that the problem arose because of expansion of the backfill caused by reaction of lime in the fill to ingress of water. The overall structural integrity of the structure is not affected, but the cracked panels are unsightly and ongoing repairs are necessary. The use of expansive backfill cannot be entertained in MSE structures and the material is not recommended. (See Figure 6.)



Figure 5. Vanderbijlpark



Figure 6. Dunswart

#### 3.4.3 Recycled Asphalt (RAP)

RAP was taken as backfill on the Western Freeway Durban structure constructed during 2006. The internal angle of friction was 30° degrees. 100% passed the 20 mm sieve and zero passed the 75 micron sieve. The interlock of the binder coated aggregate fragments are subject to significant residual viscous behaviour resulting in time delayed post construction creep and consolidation of the fill. In the case of the Western Freeway this led to rotation of the crash barrier during the construction process and consequent bursting of the cladding. The settlement of the fill was monitored and once it became negligible the cracked panels were repaired and the structure was brought into service. RAP, mixed 50:50 with sandstone has been successfully used on another project. RAP should not be used on its own however and should be mixed with approved backfill for use as backfill in MSE structures. (See Figures 7 & 8)



Figure 7. Western Freeway, Durban

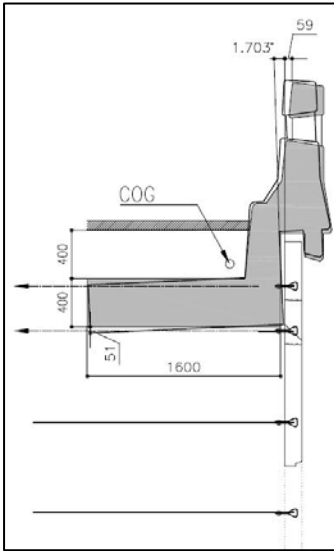

Figure 8. Barrier rotation, Full Panel

#### 3.4.4 Manufactured backfills

Single sized rock or stone resistant to weathering is an ideal backfill material for MSE structures. This type of material is free draining, construction can proceed in all weathers and the need for subsurface drains is eliminated. Compaction is not necessary and the material can be used to backfill areas inaccessible to compaction plant. It could also be used for backfill of structures in or under water. On the Ugie to Langeni Road (E Cape, RSA) rockfill has successfully been used with galvanized steel reinforcing strips, while 50mm stone was used with synthetic reinforcing strips.

The even sized material needs to be durable and not degrade over time.

A durable shale backfill has also been successfully used at the Grootegeluk Mine – Limpopo RSA.



Figure 10. Langeni –galvanized steel reinforcing strips



Figure 11. Langeni – synthetic reinforcing strips

## 4 METHODS OF LOCATING SOURCES OF BACKFILL MATERIAL

In areas and countries remote from RSA the backfill specifications form part of the contract documents and backfill sources are located by local consulting engineers and contractors. Intermediate backfills require local experience before they can be safely used and care should be taken when using them. In a few instances RESA has engaged engineering geologists to locate suitable backfill material.

Soil maps are available in certain African countries. These are geared for agriculture rather than construction but should nevertheless prove to be useful.

- Soil engineering maps are available in South Africa.
- Google Earth and GPS systems will also assist in selection of suitable backfill sources.

Data banks of materials and their properties used for MSE structures should be compiled as they are constructed.

## 5 RECOMMENDATIONS

5.1 The nature and location of the structure should determine the type of backfill which could be used. Existing National and Regional Specifications for MSE backfill should be used cautiously when designing high structures (>15 m); heavily loaded structures and bridge abutments; structures with geometries allowing differential settlements.

5.2 When intermediate backfills are used, care should be taken to prevent the ingress of water both during and after construction. In high rainfall areas the use of intermediate material with more than 20% passing the 20 micron should be avoided.

5.3 The use of intermediate backfills with more than 20% passing 20 microns should be limited to sloping structures, tiered structures and low structures (less than 6m high).

5.4 The use of steel slag and RAP (unless it is mixed with other acceptable material) is not recommended for MSE backfill.

## 6 CONCLUSIONS

6.1 The backfill is generally the most costly component of an MSE structure and the component most likely to cause problems. Careful and thorough selection is an absolute requirement.

6.2 The nature of the structure should be considered when selecting MSE backfill.

## REFERENCES

- Brink, A.B.A, 1979. Engineering Geology of Southern Africa, Volumes 1 to 4.
- Smith, A.C.S, 1999. Reinforced Earth structures for headwalls to crushing plants in Africa, Geotechnics for Developing Africa.
- October 1999. 12th Regional Conference for Africa on Soil Mechanics and Geotechnical Engineering, Durban, South Africa.