

# Innovative solution for a Kei Cutting problem

GV Price

*Jeffares & Green, East London, South Africa*

ACS Smith

*Reinforced Earth (Pty) Ltd, Johannesburg, South Africa*

A Muhajer

*South African National Roads Agency, Southern Region*

**ABSTRACT:** An innovative concept for the widening of fills over an existing sidefill has been implemented on the National Route 2 (N2) across the Great Kei River in the Eastern Cape Province of South Africa. Ten retaining walls have been constructed in which soil nails are combined with a mechanically stabilized embankment (MSE) to allow for the accommodation of traffic during construction, widening of the fills and compliance with overall stability requirements. This paper describes the reasons for the selection of this solution and the design and construction thereof. The cost and technical merits of this hybrid structure are compared to alternative solutions. The conclusion reached is that this solution economically satisfies the technical and environmental requirements and has potential to be used more extensively for widening projects in the future.

## 1 EMBANKMENT WIDENING STABILIZATION REQUIREMENTS

### 1.1 Introduction

Upgrading of National Route 2 across the Great Kei River, Eastern Cape of South Africa comprises a multi-million dollar project in which a narrow, torturous route is widened from two lanes to three lanes. The area presents a rugged topography through a sinuous valley and on slopes that are steep and already close to their natural angle of repose. This terrain and poor alignment of the existing route, combined with the high rainfall of the area, presents a number of challenges of which the realignment and widening of sections of the road out and over the existing fill is the subject of this paper.

### 1.2 Requirements

The northern side of what is locally known as the Kei Cuttings, comprises a road characterised by high, steep cliffs on the upslope side of the road and long relatively steep embankment fills on the downslope side. The existing embankment slopes are relatively devoid of vegetal cover as a result of the inert nature of the fill material, and the lack of topsoil. This torturous, steep and dangerous section of the road requires widening to enable safe passing and adequate sight distance. Cutting into the high upslope cliffs would be both impractical and costly so that any widening would have to take place on the downslope side. This makes for difficult geotechni-

cal engineering as the existing embankment slopes are on average 32° steep, although these do vary over quite a large range from as little as 23° to as steep as 49°.

### 1.3 *In situ* conditions

Investigations for the project included borehole drilling and trial pitting. Field tests were conducted on site and samples were removed for laboratory testing. Laboratory results indicated material with a cohesion (kPa) that varied between 2 and 22 kPa and a friction angle (°) varying between 29 and 38°. A sensitivity analysis indicated that the angle of friction ( $\phi$ ) to be used should be 32° with a cohesion (c) of 5 kPa. Stability analyses of existing slopes were undertaken using the Bisjan programme, which assesses the stability using the methods of both Bishop and Janbu. Stability analyses using these results indicated that the existing embankment slopes were only marginally stable and on the brink of failure. Decreasing the phreatic surface to beneath the embankment fill results in a Factor of Safety of 1.1. However, when the phreatic surface is allowed to climb into the fill the factors of safety drop dramatically. By implication, these slopes in their pre-construction state were either unstable or bordering on instability. Fortunately, investigations indicated that the embankment material was fairly porous with interconnected voids that allowed free passage of excess water out of the system. Ironically this occurred as a result of a previous lack of

compaction during construction of the original embankment some 3 or 4 decades ago. The fact that these slopes were already in a marginal state with respect to stability made the option of widening even more difficult.

After considering all the information to hand, and stability analyses undertaken, an MSE structure was deemed to be the optimum solution and Reinforced Earth (Pty) Ltd was nominated to undertake the work.

#### 1.4 Scheme Alternatives

These included *inter alia* options such as:

- Cantilever pile walls with lagging
- Contiguous pile walls
- Secant pile walls
- Reinforced concrete retaining walls
- Crib walls
- Gabions
- Soil reinforcement (MSE, soil nailing) .

MSE was chosen for this project because it was cost effective, did not require rock foundations and could accommodate differential settlements. The construction technique was simple and labour intensive, reducing the requirement of large construction machinery on the steep slopes. Reinforced Earth<sup>®</sup> was chosen as being the best suited MSE system for this particular task.

#### 1.5 Original tender design

Reinforced Earth's TerraTrel<sup>®</sup> system was specified in the tender documents. In order to enhance the overall stability of the existing fill, even when surcharged with this new MSE structure, the reinforcing strip length was extended until it nicked into the underlying rock slope as shown in Figure 1. The type of structure specified was economical and flexible enabling it to adjust to settlement of the underlying fill. In addition it would provide a pleasing natural rock appearance satisfying environmental requirements. In order to accommodate a single lane of traffic, temporary shoring of the excavation for the TerraTrel<sup>®</sup> mass was envisaged.

## 2 ACTUAL SOLUTION SELECTED

### 2.1 The problem

On award of the contract, it was decided that two-way traffic needed to be maintained during the construction process. The specified TerraTrel<sup>®</sup> structures were too wide and massive to accommodate two-way traffic as shown in Figure 1 and an alternative system for the retaining walls, which would meet all the requirements, was urgently required. This left an unenviable situation for the embankment widening designers. First of all the

original embankment would have to be rehabilitated to a factor of safety of at least 1.3. This is in terms of Client requirements for safe embankment design. The 1989 Code of Practice for Lateral Support of Surface Excavations too, as required by the Geotechnical Division of the South African Institution of Civil Engineers, states..... "It is generally accepted that the factor of safety should not be less than 1.5 for permanent work". This meant cutting into the existing embankment slopes, stabilising them to a factor of safety between 1.3 and 1.5, depending on the moisture regime and knowledge of the insitu materials, and once this open cut has been stabilised, to then construct the widening using an MSE structure. So not only did the original embankment have to be improved to a much higher factor of safety, but also some method was required whereby the two systems could be tied together, and the overall stability of the entire combination guaranteed safety factor values in excess of 1.3 and possibly 1.5.

### 2.2 The solution – combined soil nail and MSE structure

Following discussions between all parties an innovative and economical solution was proposed. This solution required a combination of a nailed system and a much narrower MSE mass. A typical cross-section of the composite soil nail and MSE structure is shown in Figure 2. This solution allows for the accommodation of two-way traffic; limits the excavation required for the MSE mass; satisfies the internal stability requirements of both the temporary nailed structure and the MSE structure, the composite nailed / MSE structure and also the overall stability requirements of the widened embankment. Finally, it provides a pleasing natural visual appearance.

### 2.3 The MSE system

An MSE structure is a composite structure comprising frictional earth, reinforcing strips and a cladding. In this project the TerraTrel<sup>®</sup> system comprised a backfill which was a completely, highly weathered dolerite with 100% passing a 5 mm sieve and 10% by mass passing a 20 micron sieve. For design purposes an internal angle of friction of 36° and a cohesion of zero was assumed for this material. The pH of the backfill was 6.5 and the material easily complied with electro-chemical characteristics required to ensure the design service life of 100 years. The reinforcing strips were hot dip galvanized medium tensile ribbed steel strips, with cross-section 60mm x 4 mm. The length of the strip is dependent on the height of the wall. Only 3.5 m and 4 m strip lengths were used on this project for structures up to 8 m high. The cladding is shown in Figure 3.

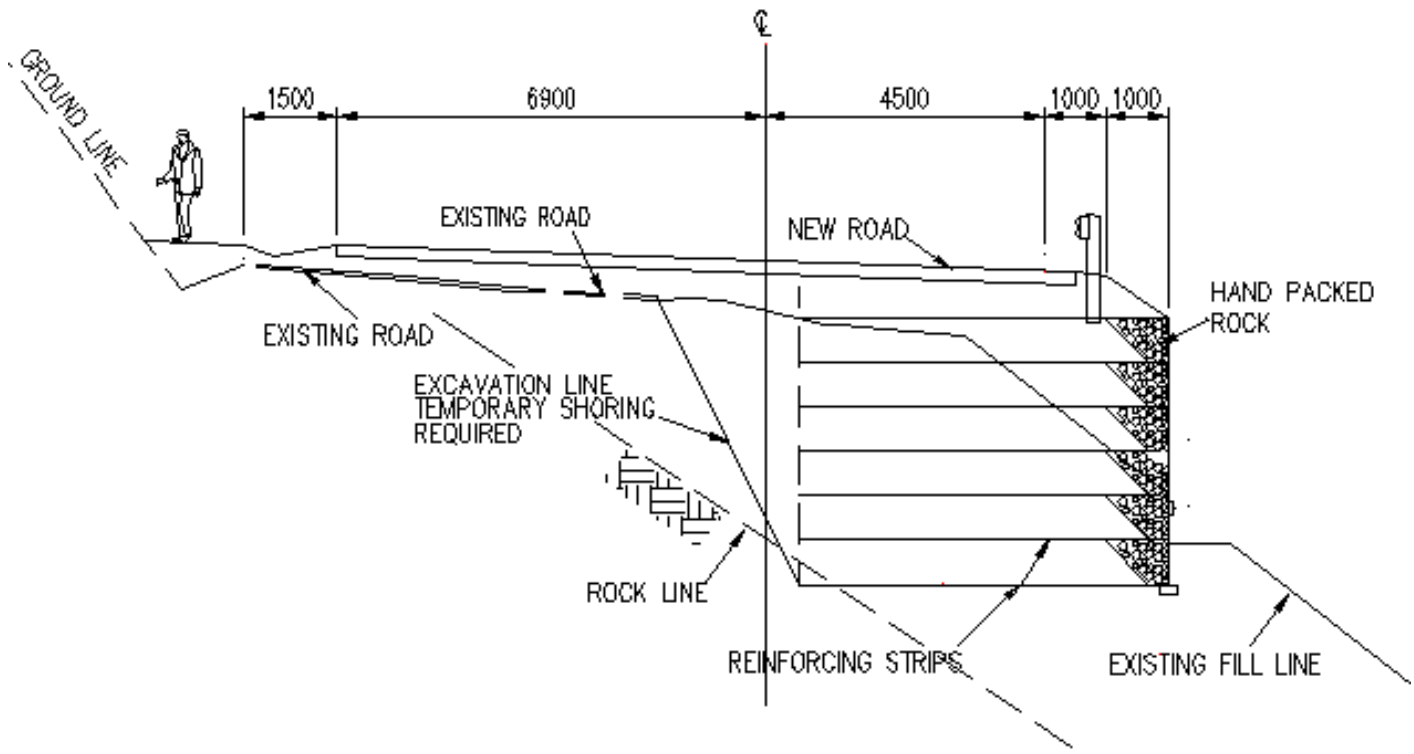

Figure 1. Typical cross section of the specified MSE solution.

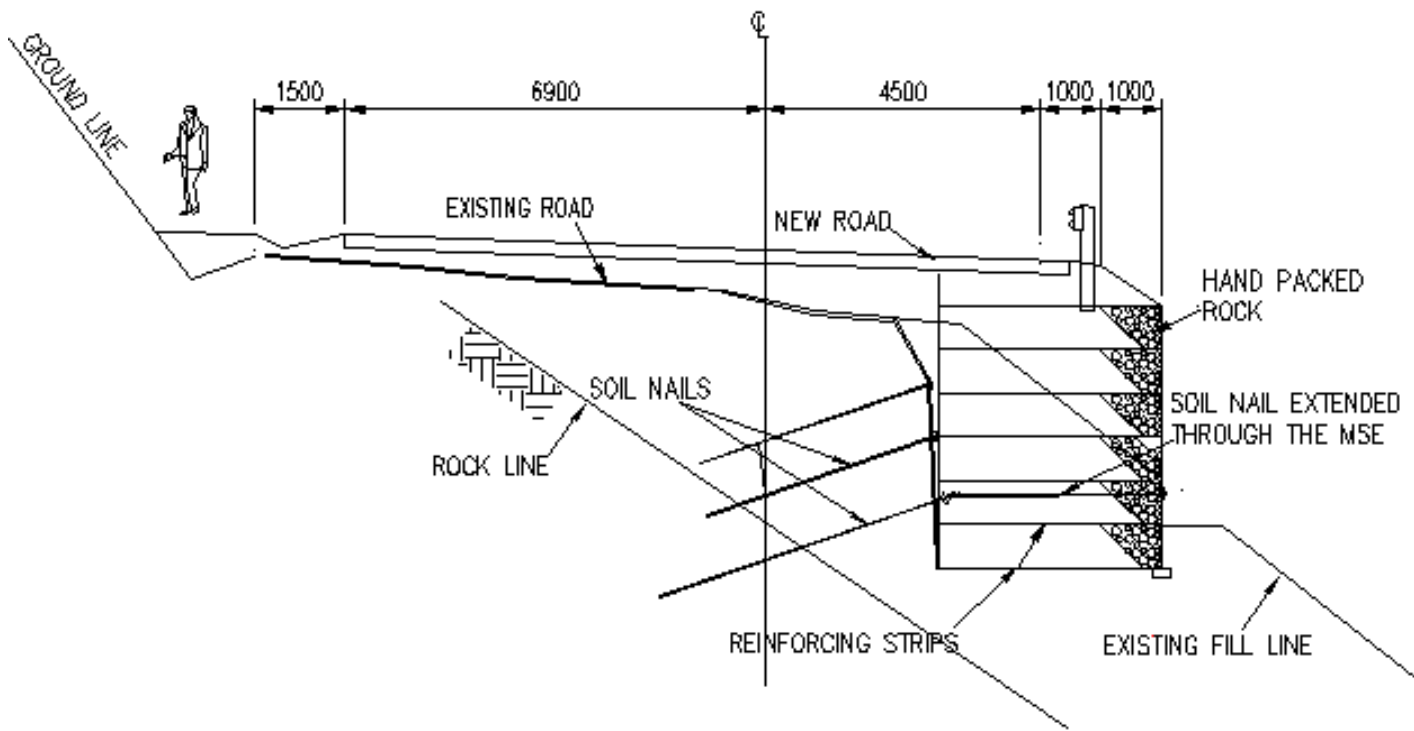

Figure 2. Typical cross section of the composite soil nail / MSE structure.

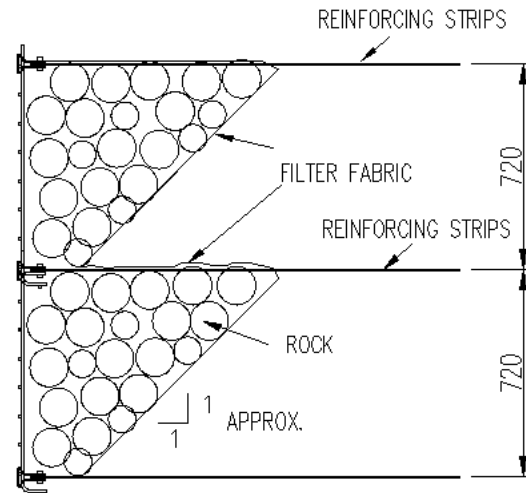
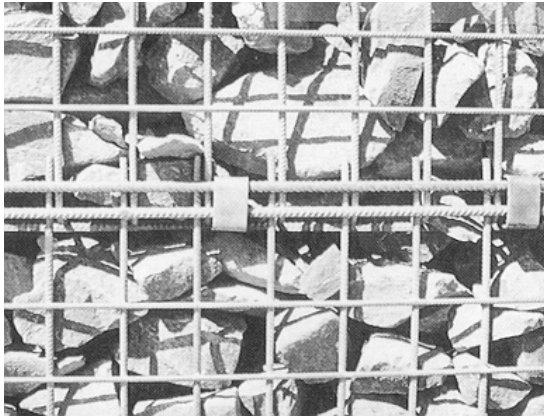

Figure 3. The TerraTrel<sup>®</sup> cladding.

It comprises a heavy hot dip galvanized weldmesh made up of 8 mm, 10 mm and 12 mm bars with a 100 mm by 100 mm opening. The elements are bound together by tie points, onto which the reinforcing strips are bolted. The elements are designed to concertina rather than bulge should internal settlement of the fill immediately behind the cladding occur. In order to prevent the backfill spilling through the weldmesh it is backed with a durable rock which in turn is backed with a geofabric.

The TerraTrel<sup>®</sup> system was introduced into Southern Africa in 1988 and the particular type of system described above has been used since 1995.

### 3 DESIGN

#### 3.1 The MSE

On account of the space constraints, the MSE structures are designed to be as narrow as possible. The maximum strip length is 4 m and this, in many areas, is only 50% of the overall height of the structure. The internal stability of the wall is designed according to the standard local equilibrium method and satisfies reinforcing strip strength, friction and durability requirements.

#### 3.2 The nails

The nailed structure was designed to satisfy two requirements, viz.

- short term stability of the existing road while construction of the MSE was underway
- overall stability of the combined MSE / soil nail structure

The nails used were 25 mm diameter threaded bars, 3.5 m to 7.0 m long.

The top row of nails was installed approximately 2 m below the top of the excavation. The middle and bottom rows were positioned at 2 m vertical intervals beneath the top row. The horizontal spacing varied between 2.0 m and 1.5 m. All nails that were to be extended through the MSE mass were designed as permanent nails, the others, together with the permanent nails, were only required to temporarily support the road until the MSE was constructed.

#### 3.3 The combined MSE / nailed structure

A slip circle analysis through the nailed and MSE structures indicated that the critical slip would pass between the two structures and overall stability of the widened embankment was much the same as the original embankment. In order to enhance the overall stability of the widened embankment, it was necessary to combine the structures and this was done by extending the nails through the MSE mass. Details of this innovative nail extension solution are shown in Figure 4.

The height of the slopes below the retaining walls is much greater than the height of the retaining walls themselves. It is thus unreasonable to expect the retaining walls to improve the factor of safety of the entire slope. A philosophy of limiting the analysis of the overall stability of the embankment to a depth of three times the height of the wall was applied to determine the factor of safety of the slope in the region of the retaining walls.

The walls vary in height from 2 panels high (1.52m) to 10 panels high (7.28m). The slope stability program Talren was used to perform the analysis, and each section was evaluated for values of  $\phi$  ranging from 30° to 36°. The cohesion was assumed to be 5 kPa in the original fill and 10 kPa in the rock.

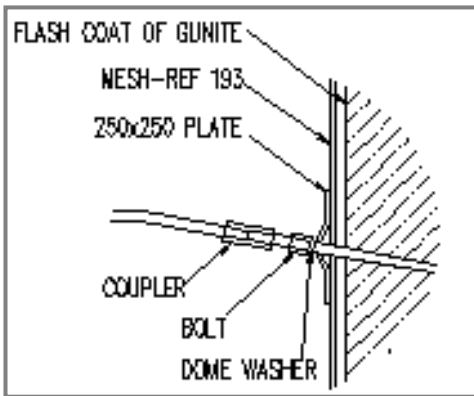

Detail 1. At the cut face.

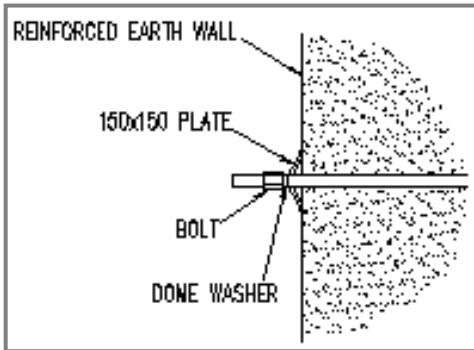

Detail 2. At the MSE cladding.



Figure 4. Detail of the nail extension.

An example of the analysis of the overall stability of the road where the retaining structure is 6 panels or 4.4 m high is illustrated in Figure 5. Two layers of soil nails, spaced at 1.7m horizontal intervals, have been provided at this section. The reinforcing strips are 4.0m long, with the number of reinforcing strips per 3m width of wall varying between 3 and 5. Figure 5 gives the factors of safety for overall stability

of this typical section for values of the angle of internal friction ( $\phi$ ) ranging from  $30^\circ$  to  $36^\circ$ . The factors range from 1.22 to 1.43, indicating that it is stable. Since the original slope of the ground beneath the road was only marginally stable the adopted solution has improved the overall stability of the existing embankment in the vicinity of the retaining structures.

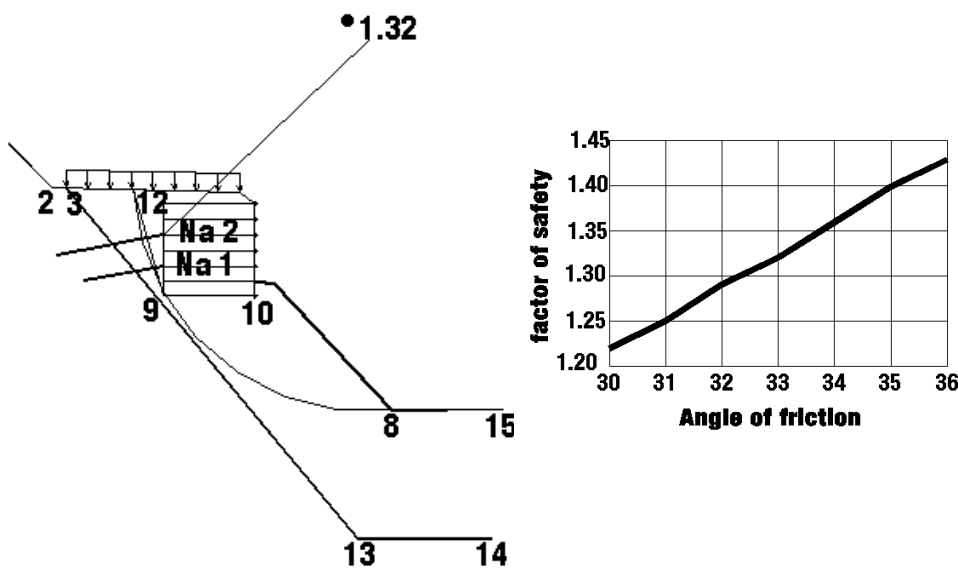

Soil no	1	2	3
$\gamma$	20	18	30
$\Gamma s1$	1	1	1
c	0	5	10
Ac(z)	0	0	20
$\Gamma C$	1	1	1
$\phi$	36	33	30
$\Gamma \phi$	1	1	1
qsNail	20	50	180

Units : kN meters and degrees  
Calculation method : Bishop1

Figure 5. Overall stability analysis for 4.4 m high MSE structure.

## 4 CONSTRUCTION

The position of the first cut for the nailed structure had to be carefully surveyed. The toe of the cut was to be 4 m from the front face of the bottom of the MSE structure and the top of the cut was not to impinge on the existing road surface. In many areas this required a full height near vertical cut, while in others a battered slope from the edge of the road was possible before the excavation had to become near vertical at a position 4 m back from the face line. Immediately after excavation of a lift, a flashcoat of gunite was applied to the face to stabilize it prior to placement of a light mesh and gunite to prevent localized spalling.

The first row of nails was positioned approximately 2 m below the shoulder breakpoint or at the position where the batter became vertical. Holes of approximately 100 mm in diameter for the 25 mm diameter threaded nails were drilled. The nails were then positioned into the holes with spacer rings and the holes were then grouted up by tremmying from the back. A headplate and dome washer and nut were placed and the nail cut some 200 mm proud of the nut.

The second and third lifts proceeded in the same way. It was not necessary to mesh and gunite beneath the lowermost nail.

The MSE construction was then able to commence in the standard way. Levelling pads are placed beneath the cladding and the repetitive cycle, of placement of backfill, cladding and reinforcing strip, is begun.

All construction takes place from behind the cladding which is a definite advantage from both construction and environmental points of view. When the level of backfill reached the first level of soil nails then the designated permanent nails were extended through the MSE mass by means of couplers, cranked nails and additional headplates, nuts and dome washers fastened outside the MSE cladding.

## 5 COST ANALYSIS

When compared to the other alternatives investigated and discussed in the first part of this paper it is found that the hybrid soil nail and Reinforced Earth solution was approximately 10% more economical than the next most economical solution and approximately 35% less than the most expensive solution. It was therefore not only an innovative way of solving a difficult problem but, as it turns out, was also a relatively economical solution.

## 6 CONCLUSION

The combined MSE / soil nail solution has proved to be a practical and economical solution for the road widening project. It has also satisfied the technical and environmental requirements of the project.

It is felt that the principle of this solution can be economically applied to road widening projects in general, wherever space is limited and, in particular, when traffic needs to be accommodated on the existing road.

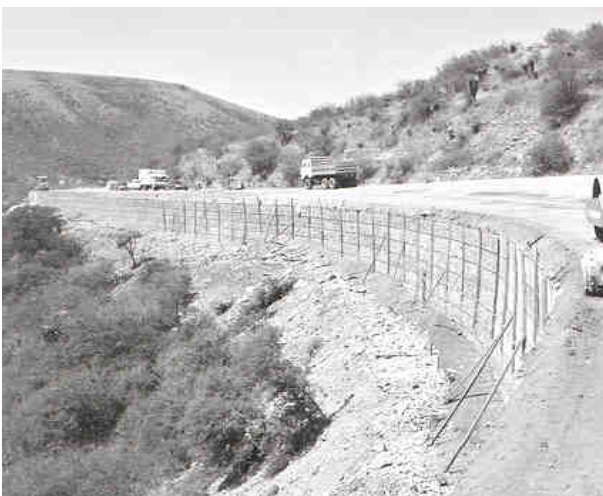

Figure 6. A view of a completed structure.



Figure 7. MSE construction and nail extension underway.